

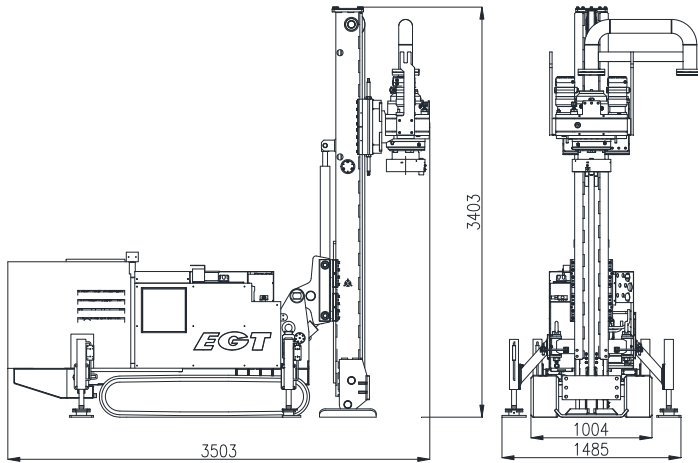

Data Sheet 27/03/17

**VERTICAL RIG
CFA COMPACT
MODEL: VD Class1**



HIGH PERFORMANCE , COMPACT CLASS 1 VERTICAL DRILL RIG MODEL VD110 FOR VERTICAL DRILLING IN CONFINED SPACES COMPLETE OF 4" CFA SWIVEL JOINT

PERFORMANCE DATA

		MAST	
PULLBACK FORCE	N	60.000	
THRUST FORCE	N	30.000	
ROTARY STROKE	mm	1.600	
ROTARY TRAVEL SPEED (MAX)	m/min	15	
RIG WEIGHT (BASIC RIG, DRY WEIGHT)	kg	3.300	

ENGINE OPTIONS

		VD110	
ENGINE MAKE / MODEL		Hatz	
ENGINE POWER	kw (hp) @rpm	55/75 @ 2.500	
OIL FLOW	L/min	157	
OIL TANK	L	155	
FUEL TANK	L	50	

ROTARY OPTIONS

SINGLE ROTARY PERFORMANCE

		R01500RH	
LOWER RANGE	Nm @ rpm	15.000 @ 11	
HIGHER RANGE	Nm @ rpm	9.500 @ 20	



STANDARD FEATURES

↻ CRAWLER

Rubber crawler.

↻ MAST

High tensile steel with power chain driven by a hydraulic cylinder positioned inside the mast.

↻ ROTARY TROLLEY

Smooth rotary travel along the mast is guaranteed using teflon sled.

↻ ENGINE

Euro4 diesel engine

↻ CONTROLS

Drilling and track controls are commanded using a cable remote control panel to improve operator safety and general rig manoeuvrability.

Rig positioning is controlled from the main control panel on the rig body.

↻ SOUNDPROOF ENCLOSURE

The power unit is protected by a soundproof compartment to reduce sound output and improve operator comfort.

↻ ACCESSORIES AVAILABLE ON REQUEST

Note: The following items can be added to the standard drill rig dressing **upon request**. In some cases, the components are **REPLACED** by alternative items. Different combinations may affect declared performance data.

A000200EV	ELECTRIC GATE VALVE				
A030081LO	LINE OILER				
C045220ES	CLAMP				
Y000100CL	CLAMP FORCE LIMITER				
P050050WT	TRIPLEX WATER PUMP				
P015150WT	TRIPLEX WATER PUMP				
W080025ST	WINCH				
Y000100FB	FORCE BALANCING KIT				

E.G.T. S.r.l.
Via Berna 1 loc. Interporto
43010 Bianconese di Fontevivo
Parma - Italy

Tel +39 (0521) 6185121
E-mail info@egt.it
Web www egt.it

DISTRIBUTED BY: