

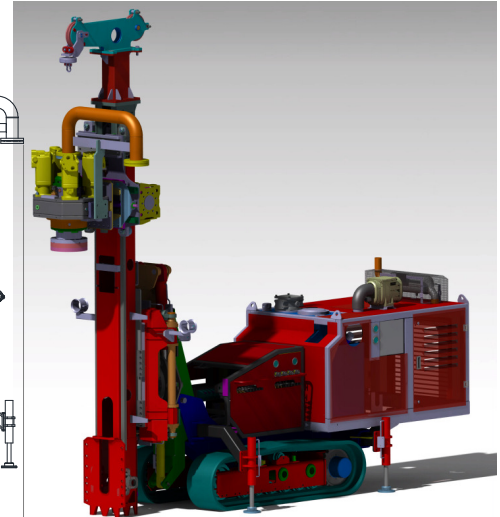

Data Sheet 11/09/15

**CLASS 2 VERTICAL RIG
AUGER DRILLING
MODEL: VD210**

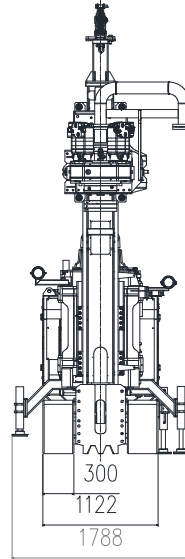
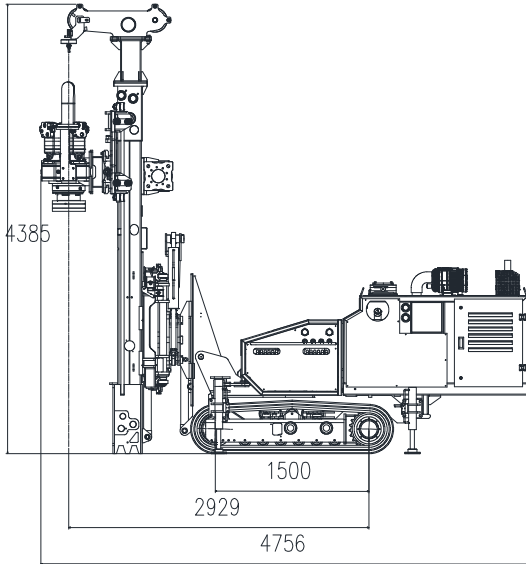

HIGH PERFORMANCE , COMPACT CLASS 2 VERTICAL DRILL RIG MODEL VD210 FOR VERTICAL DRILLING

PERFORMANCE DATA

		MAST
PULLBACK FORCE	N	120.000
THRUST FORCE	N	60.000
ROTARY STROKE	mm	1.700
ROTARY TRAVEL SPEED (MAX)	m/min	25
RIG WEIGHT WITH PU (BASIC RIG, DRY WEIGHT)	kg	6.000

ENGINE OPTIONS

		VD210
ENGINE MAKE / MODEL		VM 753IE
ENGINE POWER	kW (hp) @rpm	73 (100) @ 2.600
OIL FLOW	L/min	157
OIL TANK	L	155
FUEL TANK	L	70

ROTARY OPTIONS

SINGLE ROTARY PERFORMANCE

		R003200RH
LOWER RANGE	Nm @ rpm	32.000 @ 14
	Nm @ rpm	20.000 @ 21
HIGHER RANGE	Nm @ rpm	15.000 @ 30
	Nm @ rpm	10.000 @ 42



Data Sheet 11/09/15

**CLASS 2 VERTICAL RIG
AUGER DRILLING
MODEL: VD210**

STANDARD FEATURES

↻ CRAWLER

Steel crawler with steel track shoes.

↻ MAST

High tensile steel with power chain driven by a hydraulic motor positioned on the lower side of the mast.

↻ ROTARY TROLLEY

Smooth rotary travel along the mast is guaranteed using adjustable bearings.

The Slidramatic side slide allows off-axis trolley shift to improve access.

↻ ENGINE

VM engine (Euro 4)

↻ CONTROLS

Drilling and track controls are commanded using a cable remote control panel to improve operator safety and general rig manoeuvrability.

Rig positioning is controlled from the main control panel on the rig body.

↻ SOUNDPROOF ENCLOSURE

The power unit is protected by a soundproof compartment to reduce sound output and improve operator comfort.

CONFIGURATION

↻ DRESSING

The Class 2 Vertical rig can be configured for:

- Rotary drilling
- Top hammer drilling
- Down the hole hammer drilling
- Jet grouting
- Mast opening system

↻ ACCESSORIES AVAILABLE ON REQUEST

Note: The following items can be added to the standard drill rig dressing **upon request**. In some cases, the components are **REPLACED** by alternative items. Different combinations may affect declared performance data.

A000200PV	PNEUMATIC VALVE	P050050WT	TRIPLEX WATER PUMP	X000100DR	DATA RECORDER
A000200EV	ELECTRIC GATE VALVE	P015150WT	TRIPLEX WATER PUMP	X000100ID	INCLINOMETER DISPLAY
A030081LO	LINE OILER	R000975RH	ROTARY HEAD	X000100JT	JET GROUTING TIMER
C045220ES	CLAMP	R000090HC	HYDRAULIC CHUCK	Y000100CL	CLAMP FORCE LIMITER
C058320ES	CLAMP	R000140HC	HYDRAULIC CHUCK	Y000100FB	FORCE BALANCING KIT
E000100PT	POWER UNIT TRAILER	R530850CK	CORING KIT		
K000901MO	MAST OPENING SYSTEM	S114450ST	SWIVEL JOINT		
M000330MX	MAST EXTENSION	V000500CW	COUNTERWEIGHT		
M000660MX	MAST EXTENSION	W130046ST	WINCH		
M001000MX	MAST EXTENSION	W130046CK	COMPACT WINCH KIT		
M075001JX	JET GROUTING EXTENSION	W130046CW	COMPACT WINCH		

E.G.T.E S.r.l.

Via Berna 1 loc. Interporto
43010 Bianconese di Fontevivo
Parma - Italy

Tel +39 (0521) 618521
E-mail info@egt.it
Web www.egt.it

DISTRIBUTED BY:

E.G.T. RESERVES THE RIGHT TO MODIFY DATA WITHOUT GIVING PRIOR NOTICE.
BECAUSE OF DIFFERENT NORMS, IMAGES, DATA AND ILLUSTRATIONS ARE INDICATIVE AND HENCE NOT BINDING

This is equipment